

Investigation of Brake Force Distribution for Three axle Double Deck Bus in Thailand

Saiprasit Koetnuyom¹ and Songwut Mongkonlerdmanee²

The Sirindhorn International Thai-German Graduate School of Engineering (TGGS)
 King Mongkut's Institute of Technology North Bangkok,
 Bangsue, Bangkok 10800, Thailand

Tel: 0-25870026, Fax: 0-25869541, ¹ E-mail: saps@kmitnb.ac.th ² E-mail: songwut41@hotmail.com

Abstract

Brake force distribution is the main topic for safety in the vehicle. Normally, large proportion of brake force distribution is designed in the front wheels due to the additional dynamics load. However, if greater front wheel brake force is applied, the vehicle will require high quality of road friction in order to avoid the wheel lock condition. Without automotive engineering knowledge, the vehicle is subjected to either instability condition while braking or less braking distance. For three axles double deck bus, brake force distribution among the axles should be designed in the beginning stage of bus design. However, with Thai technicians experience in Ratchaburi province, the sizes of brake chambers are chosen for each wheel axle. For this reason, the objective of this research is to investigate the brake force distribution of double deck bus based on automotive engineering knowledge. Furthermore, the engine brake is taken into account for brake force distribution. As a result, the conditions of wheel lock on various coefficients of friction are revealed. The analytical calculation of engine brake for each gear position is also illustrated to investigate the effect of engine force for different vehicle velocity.

Keywords: Brake force distribution, wheel brake lock, three wheel axle brake, engine brake

1. Introduction

Ratchaburi province has many companies to built double deck bus for using in many businesses. Almost the double deck bus has been used as the way of the intercity transportation. The process to build the bus starts from the used parts such as chassis, brake system and drive-train. However, the brake system has to be building following technician experience. Sometime, the parts of brake are used over-design in order to achieve the failure of driving safety. Furthermore, the failure of designing may be increasing the wheel locking and accident occurs. The regulation of transportation ministry in Thailand is wanted to the every companies have to the standard in the future. Therefore, rechecking brake specific and studies brake behaviors following automotive engineering knowledge can be reducing the costs and accident.

2. Bus brake system

Brake system in the bus is the full air system and using different equipment in general car, because the bus

is more required braking force. In part of transfer braking force is beginning from brake pedal is applied the air signal and is sent the air signal approximate 8 kg/cm² to brake chamber by using the relay value. Pressure in brake chamber P_e pushes the S cam r_N . After two curve the brake shoes r_T expand and press against the inner surface of a rotating drum. The drum is connected to a rotating wheel. The result of this contact produces friction and creates the braking force F_{BR} as shown in Fig. 1 and also called actual braking force which enables the bus slow down or stops. For the proportioning of brake force distribution will be designed is rigid brake force distribution. The analytical of rigid brake force distribution is based on different equipment and weight on individual axle such as sizing of twin axle brake chamber is larger than front, rear axle and another brake specification shown in table 1. The equations of actual braking force on individual wheel are applied by:

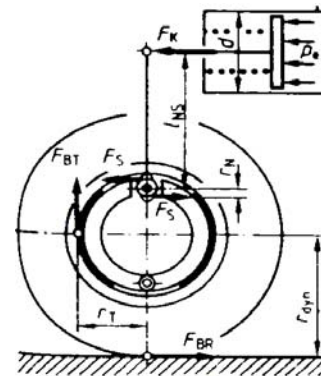

Figure 1. Drum and shoe layout [6]

$$F_K = \frac{P_e \pi d^2}{4} \quad (1)$$

$$F_s = \frac{F_K L_{NS}}{2r_N} \quad (2)$$

$$F_{BT} = F_s C \quad (3)$$

$$F_{BR} = \frac{F_{BT} r_T}{R_{dyn}} \quad (4)$$

Table 1. The parameter and values of brake specification of Nissan RF-8 Diesel Engine [1]

Parameter	Front wheel	Twin wheels	Rear wheel
Diameter of the brake chamber, d (m)	0.13	0.17	0.13
Pressure in the brake chamber, P_c (kg/cm ²)	8	8	8
Lever arm of the cam setter, L_{NS} (m)	0.16	0.155	0.16
Radius of the brake cam, r_N (m)	0.025	0.03	0.025
Radius of brake drum, r_T (m)	0.182	0.182	0.182
Characteristic value, internal transmission, C (-)	4	4	4
Dynamic wheel radius, R_{dyn} (m)	0.502	0.502	0.502

This bus has double deck and three axles shown in Fig. 2. and the parameter of three axles double deck bus shown in table 2. The dynamics load and ideal braking force problems are considered by using the free body diagram (FBD) as shown in Fig. 3. The dynamics load transfer effect induced by the longitudinal accelerations is also taken into account in the mathematical model. The value of dynamics load transfer depended on deceleration.

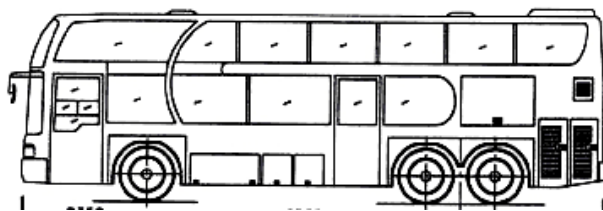

Figure 2. The three axles double deck bus

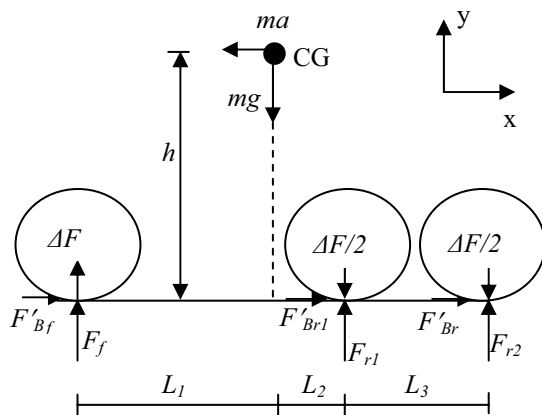

Figure 3. Free body diagram [FBD] of bus

The equations of dynamic load and ideal braking force problem are applied by:

$$F_B = \mu mg \quad (5)$$

$$\Delta F = \frac{mah}{\left[L_1 + L_2 + \left(\frac{L_3}{2} \right) \right]} \quad (6)$$

$$F_B = F'_{Bf} + F'_{Br1} + F'_{Br2} \quad (7)$$

$$F'_{Bf} = (F_f + \Delta F) \mu \quad (8)$$

$$F'_{Br1} = (F_{r1} - 0.5\Delta F) \mu \quad (9)$$

$$F'_{Br2} = (F_{r2} - 0.5\Delta F) \mu \quad (10)$$

Table 2. The parameters and values of three axles double deck bus

Parameter	Value
Distance, CG to front, twin and rear axle, L_1, L_2, L_3 (m)	4.35, 1.115, 1.265
Distance, CG of high, h (m)	1.344
Reaction force on front axle, F_f (kN)	43.949
Reaction force on twin axle, F_{r1} (kN)	79.853
Reaction force on rear axle, F_{r2} (kN)	42.968
Friction coefficient on road surface μ	-
Gravity, g (m/s ²)	9.81
Mass of bus, m (kN)	166.77

3. Adhesion factor and internal transmission

The stopping distance of a wheel is greatly influenced by the interaction of the rotating tire tread and the road surface. The relationship between the decelerating force and the vertical load on a wheel is known as the adhesion factor. This is very similar to the coefficient of friction (μ) shown in table 3. which occurs when one surface slides over the other, but in the case of a correctly braked wheel, it should always rotate right up to the point of stopping to obtain the greatest retarding resistance.

Table 3. Typical adhesion factors for various road.

Type	Concrete and Asphalt	Tar macadam
Dry	0.76-0.85	0.58-0.62
Wet	0.48-0.52	0.38-0.42
Oily	0.35-0.40	0.25-0.30

4. Engine brake

The power of engine is generated by compressing stroke. When the piston reaches to top dead center, intake and exhaust valve are close. At the same time the injector is injected the fuel to combustion chamber called power stroke. But the engine brake is friction process from engine while the driver is suddenly releasing the accelerator. The result of brake mean effective pressure in combustion chamber is resist the piston movement and defined by ideal speed. The value of resist is through to gear, differential and wheels so-called engine brake and

decried in unit of force. The engine brake can be defined by Eq. 11-15.

$$W_b = 2\pi\tau N_{eng} \quad (11)$$

$$b_{mep} = \frac{W_b}{2V_d N_{eng}} \quad (12)$$

$$V_d = \frac{\pi D^2 s}{4N_c} \quad (13)$$

The ratios of brake power in the combustion chamber and wheel power are defined by the mechanical drive-train transmission. Mechanical drive train transmission will be on the order of 75-95% [4] for modern automobile engines.

$$\eta_m = \frac{W_b}{W_{wheel}} \quad (14)$$

$$W_b = W_{wheel}\eta_m$$

$$= \tau_{wheel}\omega_{wheel}\eta_m$$

$$= F_{Bwheel}R_{dyn}\left[\frac{\omega_{eng}}{i_d i_g}\right]\eta_m$$

$$= F_{Bwheel}R_{dyn}\left[\frac{2\pi N_{eng}}{i_d i_g}\right]\eta_m$$

$$F_{Bwheel} = \frac{W_b i_d i_g}{\eta_m 2\pi N_{eng} R_{dyn}} = \frac{i b_{mep} V_d i_d i_g}{\eta_m 2\pi R_{dyn}} \quad (15)$$

where

N_{eng} = Revolution of engine	rpm
W_b = Brake power	kW
τ = Engine torque	kN.m
b_{mep} = Brake mean effective pressure	MPa
V_d = Volume displacement	m ³
D = Piston bore	mm
S = Piston stroke	mm
N_c = Number of cylinder	-
η_m = Mechanical drive-train transmission	-
W_{wheel} = Wheel power	kW
F_{Bwheel} = Engine brake force	kN
i_d = Differential ratio	
i_g = Gear ratio	

The specification of engine, gear and differential ratio are indicated the characteristics of that engine such as brake power, brake mean effective pressure and engine brake force. The value of engine specific, gear and differential ratio are shown in table 4. and 5. respectively.

Table 4. Specifications of engine [1]

Type	Nissan RF-8 Diesel Engine
Piston displacement (cm ³)	16991
N_c / Engine stroke	8/4
D/S (mm)	126 x 170
Compression ratio	17.3 : 1
Max. Power (kW)	253.6 @ 2200 rpm
Max. Torque (kNm)	1.177 @ 1200-1900 rpm
idle speed (rpm)	750

Table 5. Gear and Differential ratios [1]

Gear ratio (i_g)	Differential ratio (i_d)
1 st = 7.028:1	4.625
2 nd = 4.389:1	4.625
3 rd = 2.495:1	4.625
4 th = 1.592:1	4.625
5 th = 1:1	4.625
6 th = 0.743:1	4.625
reverse = 6.987:1	4.625

The velocities of bus (km/hr) on various gears position are designed by progressive layouts method. The progressive layout method is characterized by step jump is not constant for shifting in all gears. The shifting speed at which shifting into the next smaller gear results in the maximum speed. The velocities of bus on various gears are given by Eq. 16 and shown the result of calculated in table 6.

$$V_G = \frac{2\pi N_{eng} R_{dyn}}{i_d i_g} \quad (16)$$

Table 6. The bus velocities on various gear position.

N_{eng} (rpm)	V_G (km/hr)					
	1 st	2 nd	3 rd	4 th	5 th	6 th
0	0	0	0	0	0	0
750	4.4	7.0	12.3	19.3	30.7	41.3
1000	5.8	9.3	16.4	25.7	40.9	55.0
1500	8.7	14.0	24.6	38.6	61.4	82.5
2000	11.6	18.6	32.8	51.4	81.8	110.0
2500	14.6	23.3	41.0	64.3	102.3	137.5

5. Investigation of brake force distribution and the effective of engine brake.

For the brake system of three axle double deck bus in Ratchaburi province is rigid brake force distribution. In previous section, the actual braking force dependent on specification of brake equipment on individual axle. From table 1., the data are used for calculating actual brake force distribution and percents or ratios of brake force distribution on individual axle as shown in table 7.

Table 7. The result of calculated of actual brake force distribution on individual axle

Item	Front wheel	Twin wheels	Rear wheel
Output force of the piston rod, F_K (kN)	10.417	17.814	10.417
Clamping force at the cam, F_s (kN)	33.334	46.020	33.334
Brake force at the brake drum, F_{BT} (kN)	133.336	184.080	133.336
Brake force at the periphery of wheel, F_{BR} (kN)	96.682	13.3476	96.682
Actual brake force distribution (%)	30	40	30

However, the dynamics load transfer ΔF and deceleration of braking are effective while braking (see Fig. 3). As derived in Eq. 5 and Eq. 6 the value of dynamics load transfer is changed following the mass of bus. If the mass of bus is increasing, the value of ΔF is increasing respectively and more required ideal brake force distribution on each axle. The result of calculated of the ideal brake force distribution on front axle F'_{Bf} , twin axle F'_{Br1} and rear axle F'_{Br2} shown in table8.

Table 8. The result of calculated of ideal brake force distribution on individual axle.

μ	ΔF (kN)	F'_{Bf} (kN)	F'_{Br1} (kN)	F'_{Br2} (kN)
0	0	0	0	0
0.1	3.747	4.77	7.798	4.109
0.2	7.495	10.289	15.221	7.844
0.3	11.242	16.557	22.270	11.204
0.4	14.989	23.575	28.943	14.189
0.5	18.737	31.343	35.242	16.800
0.6	22.484	39.860	41.167	19.036
0.7	26.231	49.126	46.716	20.897
0.8	29.979	59.142	51.891	22.383
0.9	33.726	69.908	56.691	23.494
1	37.473	81.422	61.116	24.231

From the result of calculated of actual and ideal brake force distribution on individual axle can be describe in relate of wheel locking. It means that, when known braking force of twice can be built graph brake force for predicting the wheel locking (see Fig. 1) by using the assumption. The locking wheel is the state that the wheel is suddenly stopped causing the slip between wheel and road. When the wheel is locking, the slip is equal to 100%, the wheel velocity is zero and bus velocity is still remained. The reason of locking wheel has two ways that are excess braking force and friction of brake more than friction of road surface. The wheel locking behavior can describe by using the case study following the example 1 and 2. Example1. in Fig. 4 at point (a-a') following the data from table 2.and Eq. 6 and Eq. 9 reveals the cases of wheel locking on twin wheels, if the road surface is oily concrete following to table 3, the friction of road surface = 0.4 and applied braking force

$F_{Bf}' = F_{Bf} = 25$ kN . But the result of friction of brake = 0.482. Therefore twin wheels are locking because of friction of brake more than friction of road surface and excess braking force on twin wheels. But in the same condition following the example 2 in Fig. 5 at point (b-b') following the data from table 2.and Eq. 6 and Eq. 10 shown reveals the cases of rear wheel never locking. If the road surface is oily concrete following to table 3, the friction of road surface = 0.4 and applied braking force $F_{Br1}' = F_{Br1} = 30$ kN. But the result of friction of brake = 0.393. Therefore the rear wheel never locking because the friction of brake is less than the friction of road surface.

When the driving is releasing the accelerator, speed of engine reducing to idle speed are assumed. At the idle speed 750 rpm, according to Eq. 11 to 13 the engine provided the constant brake mean effective pressure. This value can be used to obtain the engine brake power at various speeds by multiplying the constant brake torque with certain engine speed and shown in table 9. This assumption can be used to approximate engine brake force because no extra torque is produced from engine while braking. The values of brake power are changed following to the gear position and various bus velocities (see table 10.). The maximum values are occurring at low gear position. If the same velocities but the gear position is different, the values of them will be not equal because the gear ratio.

Table 9. The values of brake power on various speed.

rpm	b_{mep} (MPa)	W_b (kW)
750(idle)	5.73463	75.948
1000	5.73463	101.264
1500	5.73463	151.896
1700	5.73463	172.149
1900	5.73463	192.402
2000	5.73463	202.528

The engine brake force is derived following to Eq. 15 and dependent on the gear ratio. The maximum value of engine brake force is occurring at low gear position and reducing respectively when shift up gear position (see Fig. 6 and table 11.). But at the same gear position the value of them are equally because brake mean effective pressure is fixed by relatively between every engine speed and brake power. Therefore engine brake force is independent of velocities.

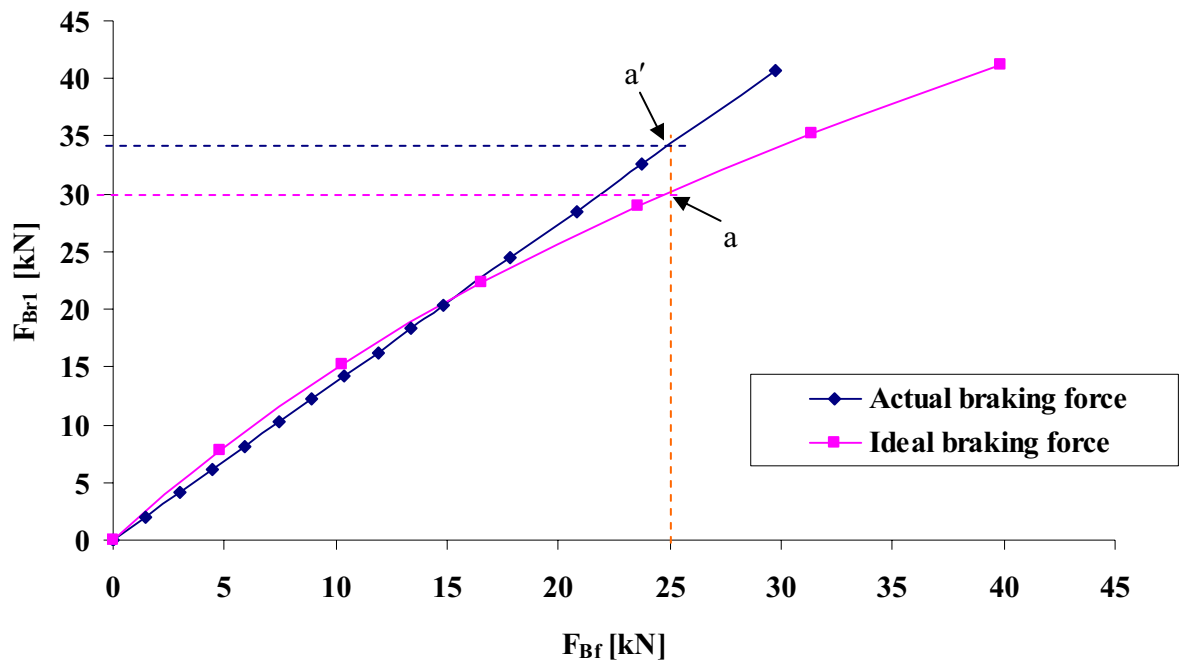

Figure 4. Example1. Actual braking force distribution between front wheel (F_{Bf}) and twin wheels (F_{Br1}) and the result of wheel locking at twin wheels, if friction of road surface = 0.4 and applied ideal braking force equal to actual braking force $F'_{Bf} = F_{Bf} = 25000$ N.

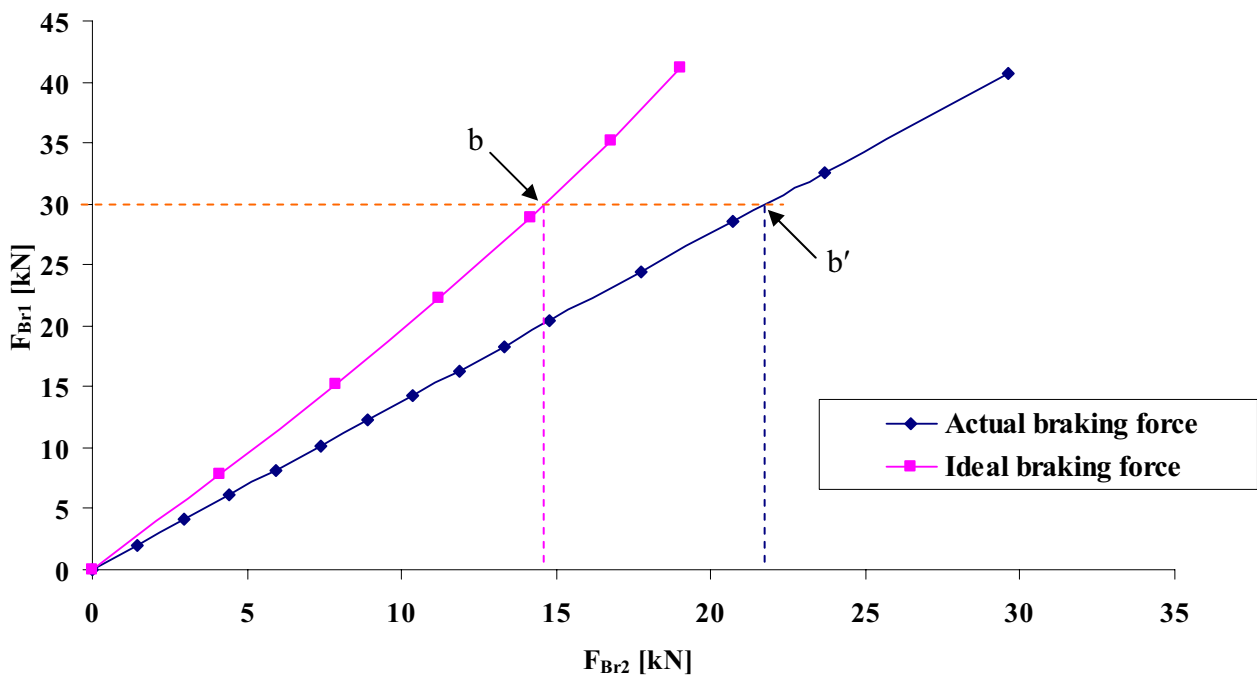

Figure 5. Example2. Actual braking force distribution between twin wheels (F_{Br1}) and rear wheel (F_{Br2}) and the result of wheel locking at twin wheels, if friction of road surface = 0.4 and applied ideal braking force equal to actual braking force $F'_{Br1} = F_{Br1} = 30000$ N.

Table 10. The brake power on each gear position and various bus velocities.

V (km/hr) \ W_b (kW)	1 st	2 nd	3 rd	4 th	5 th	6 th
100	-	-	-	-	-	184.110
95	-	-	-	-	-	174.905
90	-	-	-	-	-	165.699
85	-	-	-	-	-	156.494
80	-	-	-	-	198.026	147.288
75	-	-	-	-	185.649	138.083
70	-	-	-	-	173.273	128.877
65	-	-	-	-	160.896	119.672
60	-	-	-	-	148.519	110.466
55	-	-	-	-	136.143	101.261
50	-	-	-	196.955	123.766	92.055
45	-	-	-	177.260	111.389	82.850
40	-	-	-	157.564	99.013	73.644
35	-	-	216.169	137.869	86.636	-
30	-	-	185.288	118.173	74.260	-
25	-	-	154.407	98.478	-	-
20	-	217.293	123.525	78.782	-	-
15	260.948	162.970	92.644	59.087	-	-
10	173.966	108.647	61.763	-	-	-
5	86.983	54.323	-	-	-	-
0(idle speed)	75.948	-	-	-	-	-

Table 11. The engine brake force on each gear position and various bus velocities.

V (km/hr) \ F_{Bwheel} (kN)	1 st	2 nd	3 rd	4 th	5 th	6 th
100	-	-	-	-	-	5.965
95	-	-	-	-	-	5.965
90	-	-	-	-	-	5.965
85	-	-	-	-	-	5.965
80	-	-	-	-	8.020	5.965
75	-	-	-	-	8.020	5.965
70	-	-	-	-	8.020	5.965
65	-	-	-	-	8.020	5.965
60	-	-	-	-	8.020	5.965
55	-	-	-	-	8.020	5.965
50	-	-	-	12.763	8.020	5.965
45	-	-	-	12.763	8.020	5.965
40	-	-	-	12.763	8.020	5.965
35	-	-	20.011	12.763	8.020	-
30	-	-	20.011	12.763	8.020	-
25	-	-	20.011	12.763	-	-
20	-	35.201	20.011	12.763	-	-
15	56.365	35.201	20.011	12.763	-	-
10	56.365	35.201	20.011	12.763	-	-
5	56.365	35.201	-	-	-	-
0 (idle speed)	56.365	-	-	-	-	-

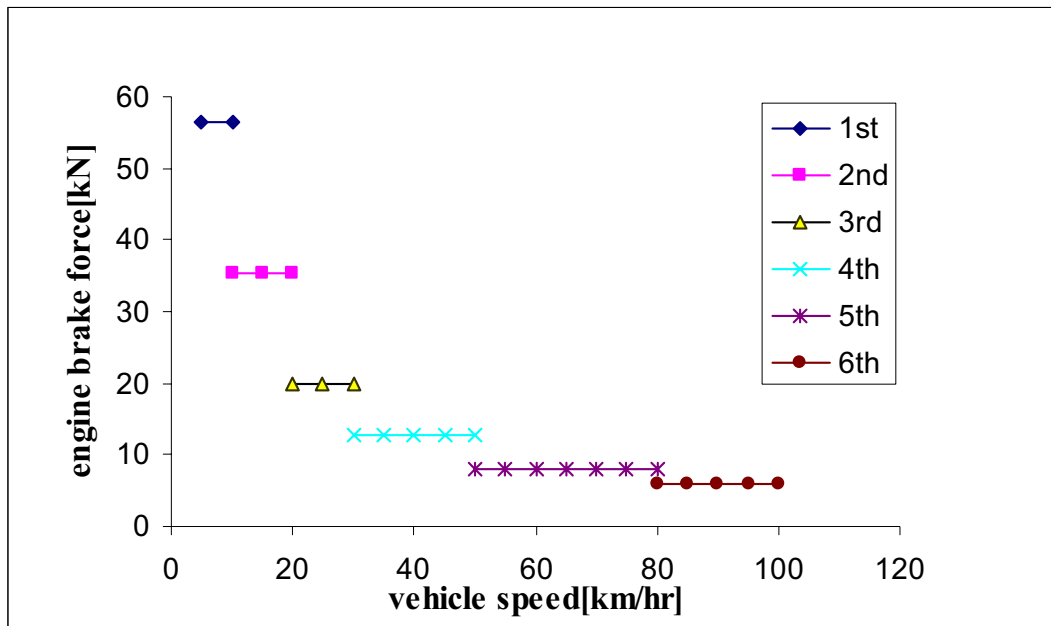

Figure 6. The relation between engine brake force and vehicle speed on each gear position.

6. Conclusion

The brake force distribution for three axle double deck bus is rigid brake force distribution or can not control braking force from brake equipment (actual braking force). At the same time when the driver applied braking force (ideal braking force) is generated dynamics load transfer in front axle and required high quality of road friction and amount of braking force in front axle more another axle for avoid the wheel lock. The wheel locking condition can be defined by friction between tire and road and quantity of braking force on individual axle. For the engine brake force is indicated amount of friction in each gear position and compared braking force with service brake. The maximum value of them are occurring

Finally, the automotive engineering knowledge is used compare and rechecking with Thai technicians experience in bus brake system following the regulation of transportation ministry in Thailand.

References

- [1] Double deck bus in Thailand from Thong Thip Company, Ratchaburi, Thailand.
- [2] Peter C. Brooks, Vehicle Design and Performance, University of Leeds Department of Mechanical Engineering, UK.
- [3] Jack Erjavec and Robert Scharff, 1996, Automotive Technology: A Systems Approach, 2nd ed.
- [4] Pulkrabek and Willard W., 1999, Internal Combustion Engine, Prentice Hall International, Inc, London.

- [5] Henning Wallentowitz, 2004, Automotive Engineering I [Lecture in TGGS program (Thai German graduate school) for King Mongkut's Institute of Technology North Bangkok], Aachen Institut fur kraftfahrwesen AACHEN University, Germany.
- [6] Tables for the automotive trade, Wiley Eastern Limited, New Delhi.
- [7] Tec Brake Engine Brake.
<http://www.tecbrake.net/home.htm>. (May 2006)